

HSSE-Schlitzfräser HSSE groove milling cutters

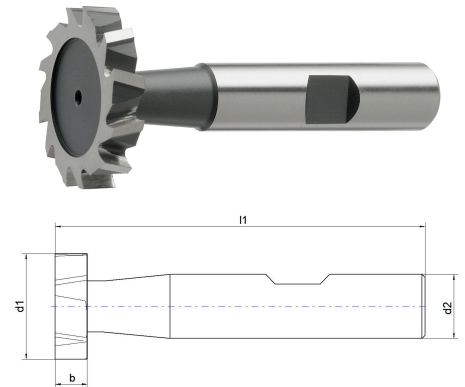

Artikelnummer Article-No.	d1 h12	b e8	l1	d2 h6	Zähne
E.9620.0.0450.010	4.5	1	50	6,0	6
E.9620.0.0750.015	7.5	1.5	50	6,0	6
E.9620.0.0750.020	7.5	2	50	6,0	6
E.9620.0.1050.020	10.5	2	50	6,0	6
E.9620.0.1050.025	10.5	2.5	50	6,0	6
E.9620.0.1050.030	10.5	3	50	6,0	6
E.9620.0.1350.020	13.5	2	56	10,0	6
E.9620.0.1350.030	13.5	3	56	10,0	6
E.9620.0.1350.040	13.5	4	56	10,0	6
E.9620.0.1650.030	16.5	3	56	10,0	6
E.9620.0.1650.040	16.5	4	56	10,0	6
E.9620.0.1650.050	16.5	5	56	10,0	6
E.9620.0.1950.030	19.5	3	63	10,0	8
E.9620.0.1950.040	19.5	4	63	10,0	8
E.9620.0.1950.050	19.5	5	63	10,0	8
E.9620.0.1950.060	19.5	6	63	10,0	8
E.9620.0.2250.040	22.5	4	63	10,0	8
E.9620.0.2250.050	22.5	5	63	10,0	8
E.9620.0.2250.060	22.5	6	63	10,0	8
E.9620.0.2250.080	22.5	8	63	10,0	8
E.9620.0.2550.050	25.5	5	63	10,0	10
E.9620.0.2550.060	25.5	6	63	10,0	10
E.9620.0.2850.060	28.5	6	63	10,0	10
E.9620.0.2850.080	28.5	8	63	10,0	10
E.9620.0.2850.100	28.5	10	71	12,0	10
E.9620.0.3250.060	32.5	6	71	12,0	10
E.9620.0.3250.070	32.5	7	71	12,0	10
E.9620.0.3250.080	32.5	8	71	12,0	10
E.9620.0.3250.100	32.5	10	71	12,0	10
E.9620.0.3850.080	38.5	8	71	12,0	10

PRODUKTDATENBLATT

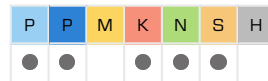

Artikelnummer Article-No.	d1 h12	b e8	l1	d2 h6	Zähne
E.9620.0.4550.080	45.5	8	71	12,0	12
E.9620.0.4550.100	45.5	10	71	12,0	12



Individuelle Schnittdaten online im
Schnittdaten-Rechner berechnen lassen:
Calculate individual cutting
data online in the cutting data calculator
www.nachreiner-schnittdaten.eu

Materialbezeichnung material description	Bearbeitung Process	Vc m/min	fz											
			∅ 4.50	∅ 7.50	∅ 10.50	∅ 13.50	∅ 16.50	∅ 19.50	∅ 22.50	∅ 25.50	∅ 28.50	∅ 32.50	∅ 38.50	∅ 45.50
PA allg. Stähle General steels	Schruppen roughing	40.00	0.006	0.008	0.010	0.015	0.025	0.035	0.040	0.045	0.050	0.060	0.065	0.070
	Schlichten finishing	40.00	0.006	0.008	0.010	0.015	0.025	0.035	0.040	0.045	0.050	0.060	0.065	0.070
	Schruppen roughing	35.00	0.006	0.008	0.010	0.015	0.025	0.035	0.040	0.045	0.050	0.060	0.065	0.070
	Schlichten finishing	35.00	0.006	0.008	0.010	0.015	0.025	0.035	0.040	0.045	0.050	0.060	0.065	0.070
	Schruppen roughing	35.00	0.006	0.008	0.010	0.015	0.025	0.035	0.040	0.045	0.050	0.060	0.065	0.070
	Schlichten finishing	35.00	0.006	0.008	0.010	0.015	0.025	0.035	0.040	0.045	0.050	0.060	0.065	0.070
	Schruppen roughing	25.00	0.006	0.008	0.010	0.015	0.025	0.035	0.040	0.045	0.050	0.060	0.065	0.070
	Schlichten finishing	25.00	0.006	0.008	0.010	0.015	0.025	0.035	0.040	0.045	0.050	0.060	0.065	0.070
	Schruppen roughing	20.00	0.006	0.008	0.010	0.015	0.025	0.035	0.040	0.045	0.050	0.060	0.065	0.070
	Schlichten finishing	20.00	0.006	0.008	0.010	0.015	0.025	0.035	0.040	0.045	0.050	0.060	0.065	0.070
PV Vergütungsstähle < 850N/mm ² Tempering steel < 850N/mm ²	Schruppen roughing	35.00	0.006	0.008	0.010	0.015	0.025	0.035	0.040	0.045	0.050	0.060	0.065	0.070
	Schlichten finishing	35.00	0.006	0.008	0.010	0.015	0.025	0.035	0.040	0.045	0.050	0.060	0.065	0.070
	Schruppen roughing	25.00	0.006	0.008	0.010	0.015	0.025	0.035	0.040	0.045	0.050	0.060	0.065	0.070
	Schlichten finishing	25.00	0.006	0.008	0.010	0.015	0.025	0.035	0.040	0.045	0.050	0.060	0.065	0.070
	Schruppen roughing	20.00	0.006	0.008	0.010	0.015	0.025	0.035	0.040	0.045	0.050	0.060	0.065	0.070
	Schlichten finishing	20.00	0.006	0.008	0.010	0.015	0.025	0.035	0.040	0.045	0.050	0.060	0.065	0.070
K Gusseisen Cast iron	Schruppen roughing	30.00	0.006	0.008	0.010	0.015	0.025	0.035	0.040	0.045	0.050	0.060	0.065	0.070
	Schlichten finishing	30.00	0.006	0.008	0.010	0.015	0.025	0.035	0.040	0.045	0.050	0.060	0.065	0.070
	Schruppen roughing	25.00	0.006	0.008	0.010	0.015	0.025	0.035	0.040	0.045	0.050	0.060	0.065	0.070
	Schlichten finishing	25.00	0.006	0.008	0.010	0.015	0.025	0.035	0.040	0.045	0.050	0.060	0.065	0.070
	Schruppen roughing	25.00	0.006	0.008	0.010	0.015	0.025	0.035	0.040	0.045	0.050	0.060	0.065	0.070
	Schlichten finishing	25.00	0.006	0.008	0.010	0.015	0.025	0.035	0.040	0.045	0.050	0.060	0.065	0.070
N AL- und AL-Legierungen AL and AL-alloys	Schruppen roughing	45.00	0.080	0.010	0.013	0.020	0.033	0.046	0.052	0.059	0.065	0.078	0.085	0.091
	Schlichten finishing	45.00	0.080	0.010	0.013	0.020	0.033	0.046	0.052	0.059	0.065	0.078	0.085	0.091
	Schruppen roughing	40.00	0.080	0.010	0.013	0.020	0.033	0.046	0.052	0.059	0.065	0.078	0.085	0.091
	Schlichten finishing	40.00	0.080	0.010	0.013	0.020	0.033	0.046	0.052	0.059	0.065	0.078	0.085	0.091
	Schruppen roughing	35.00	0.080	0.010	0.013	0.020	0.033	0.046	0.052	0.059	0.065	0.078	0.085	0.091
	Schlichten finishing	35.00	0.080	0.010	0.013	0.020	0.033	0.046	0.052	0.059	0.065	0.078	0.085	0.091
	Schruppen roughing	50.00	0.080	0.010	0.013	0.020	0.033	0.046	0.052	0.059	0.065	0.078	0.085	0.091
	Schlichten finishing	50.00	0.080	0.010	0.013	0.020	0.033	0.046	0.052	0.059	0.065	0.078	0.085	0.091

PRODUKTDATENBLATT



Materialbezeichnung material description		Bearbeitung Process	Vc m/min	fz													
				∅ 4.50	∅ 7.50	∅ 10.50	∅ 13.50	∅ 16.50	∅ 19.50	∅ 22.50	∅ 25.50	∅ 28.50	∅ 32.50	∅ 38.50	∅ 45.50		
S	Titan Titanium	Schruppen roughing	10.00	0.006	0.008	0.010	0.015	0.025	0.035	0.040	0.045	0.050	0.060	0.065	0.070		
		Schlichten finishing	10.00	0.006	0.008	0.010	0.015	0.025	0.035	0.040	0.045	0.050	0.060	0.065	0.070		